

SASCO PRODUCTS LTD.

10 Hsley Avenue, Unit 3, Dartmouth, Nova Scotia, Canada B3B 1L3
Telephone (902) 468-2126 Fax: (902) 468-2642 www.sasco.ca

PRODUCT INFORMATION

IMPEL (BORON) RODS

PROPERTIES:

The wood preservative IMPEL® (BORON) RODS are recommended for pre-treatment and remedial protection of non-food contact wood products against fungal decay and insect attack.

IMPEL® (BORON) RODS are not effective against termites unless the wood preservative has already diffused into the wood, then there is protection against many species.

CHARACTERISTICS:

IMPEL® (BORON) RODS dissolve by means of the water penetrating or bound in the wood and transforms into the active ingredient, Boric Acid. The Boric Acid is distributed by direct transportation with the water as well as by diffusion. After some time, the concentration of the Boric Acid will reach an equilibrium in the whole of the wet wood, sapwood as well as heart wood.

If the timber becomes dry, no diffusion of the Boric Acid takes place, but on subsequent re-wetting of the wood, diffusion starts again and prevents attack by decay, fungi, and insects.

APPLICATION:

1. Drill a hole that will accommodate the IMPEL® (BORON) ROD needed. The diameter of the hole should be a little larger than the diameter of the desired rod.

Examples:

Rod Diameter (approx.)	Rod Length (approx.)	Rod Weight (approx.)	Corresponding to cm ³ of wood (max.)	Pre-drilling (wood drill)
8mm	65mm	7 grams	2000	9 - 10mm
6mm	55mm	3.5 grams	750	7 - 8mm
12mm	100mm	24 grams	6000	14mm
18mm	75mm	40 grams	10000	20mm

2. Insert the correct size and quantity of IMPEL® (BORON) RODS needed into the pre-drilled holes.
3. Cap every hole with a suitable cap (filler or putty may be used, but a cap or plug is better). You need at least a 2-3 mm space between cap, plug, putty and IMPEL® (BORON) ROD to allow for expansion on wetting.

The rate of application for IMPEL® (BORON) RODS is equivalent to 6.0 kg of Boric Acid per cubic metre of wood (6oz per cubic foot).

The IMPEL® (BORON) RODS contain 100% Anhydrous Disodium Octaborate equal to 1.45g of Boric Acid per gram of rod. The following table shows the Boric Acid equivalent for each size of IMPEL® (BORON) ROD.

Rod Dimensions (mm)	Net Weight of 1 Rod (grams) (+/-6%)	Corresponding Weight of Boric Acid per Rod
6 x 12	0.7	1.0
6 x 55	3.4	4.9
8.5 x 12	1.4	2.0
8.5 x 24	2.9	4.2
8 x 48	5.2	7.5
8 x 65	6.9	10.0
12 x 30	7.3	10.6
12 x 50	12	17
12 x 75	18	26
12 x 100	24	36
18 x 75	40	58

Please note: All sizes may not be available in Canada.

The location for placement of the IMPEL® (BORON) RODS should be in the general vicinity where the potential for decay is greatest (e.g. where end grain is exposed, joints, etc.). For the most effective installation, IMPEL® (BORON) RODS should be inserted at approximately 20cm (8 inch) intervals along the grain placed as close as 5cm (2 inch) intervals across the grain where there is a higher risk of attack.

For use in structural timber: IMPEL® (BORON) RODS should be inserted in a staggered pattern at no greater than 40cm (4" centres) over the entire affected length of the component to minimize reduction in the strength of the timber.

Precautions should be taken when used in structural timber as holes drilled in critical positions may seriously weaken the structure. Advice should be obtained from a qualified engineer where remedial treatment of load-bearing timber is required.

Note: IMPEL® (BORON) RODS will not restore strength to timber already badly decayed.

Examples of Placing IMPEL® (BORON) RODS in Posts, Beams, etc.

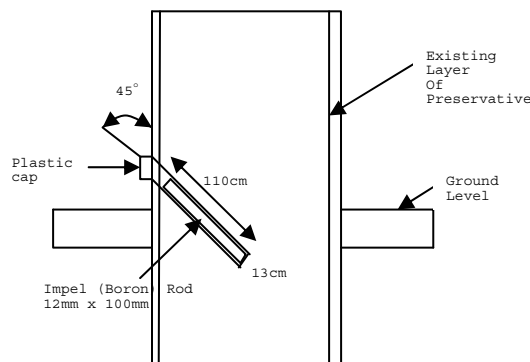

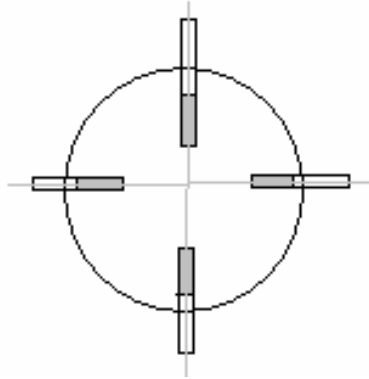

Horizontal Section Though Post, etc.
Four cross post drilling geometry

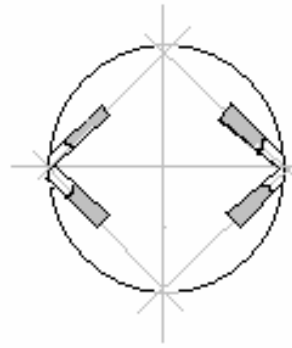

Horizontal Section Though Posts, etc.
Paired "v" post drilling geometry

Examples of Placing IMPEL® (BORON) RODS in Windows, etc.

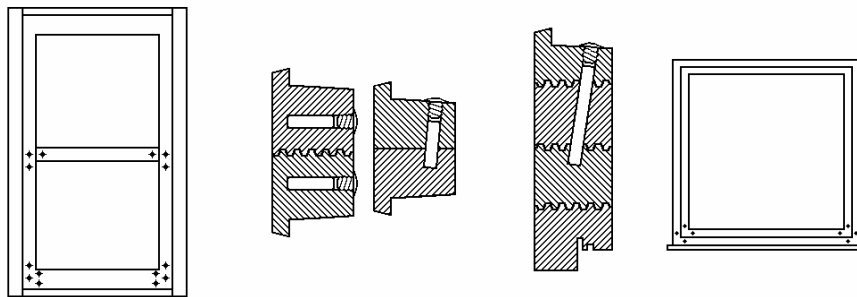

TECHNICAL ADVISORY SERVICE

Before determining the most appropriate product it is necessary to specifically identify the source of the problem, so that the best method of treatment can be applied. Technical advice of this nature is available from SASCO PRODUCTS LIMITED or your local Technical Agent.

This information given in good faith is based on many years experience and usage of similar products. However, all recommendations and suggestions are made without prejudice, since the conditions of use are beyond our control. All goods are sold in accordance with our conditions of sale, copies of which are available on request.

SASCO PRODUCTS LIMITED

10 Iisley Avenue, unit 3

DARTMOUTH, NOVA SCOTIA B3B 1L3 CANADA

Telephone: (902) 468-2126

Facsimile: (902) 468-2642

www.sasco.ca